

Rotator hidraulic CR 100

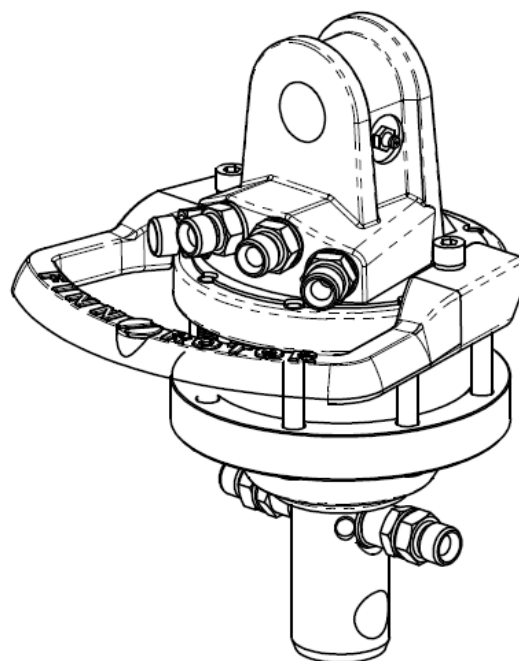
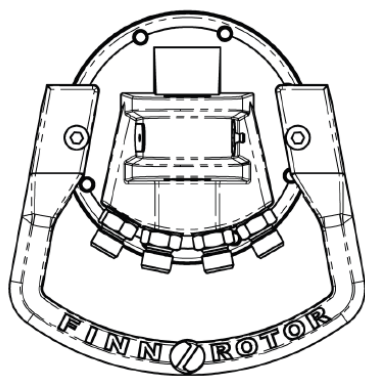
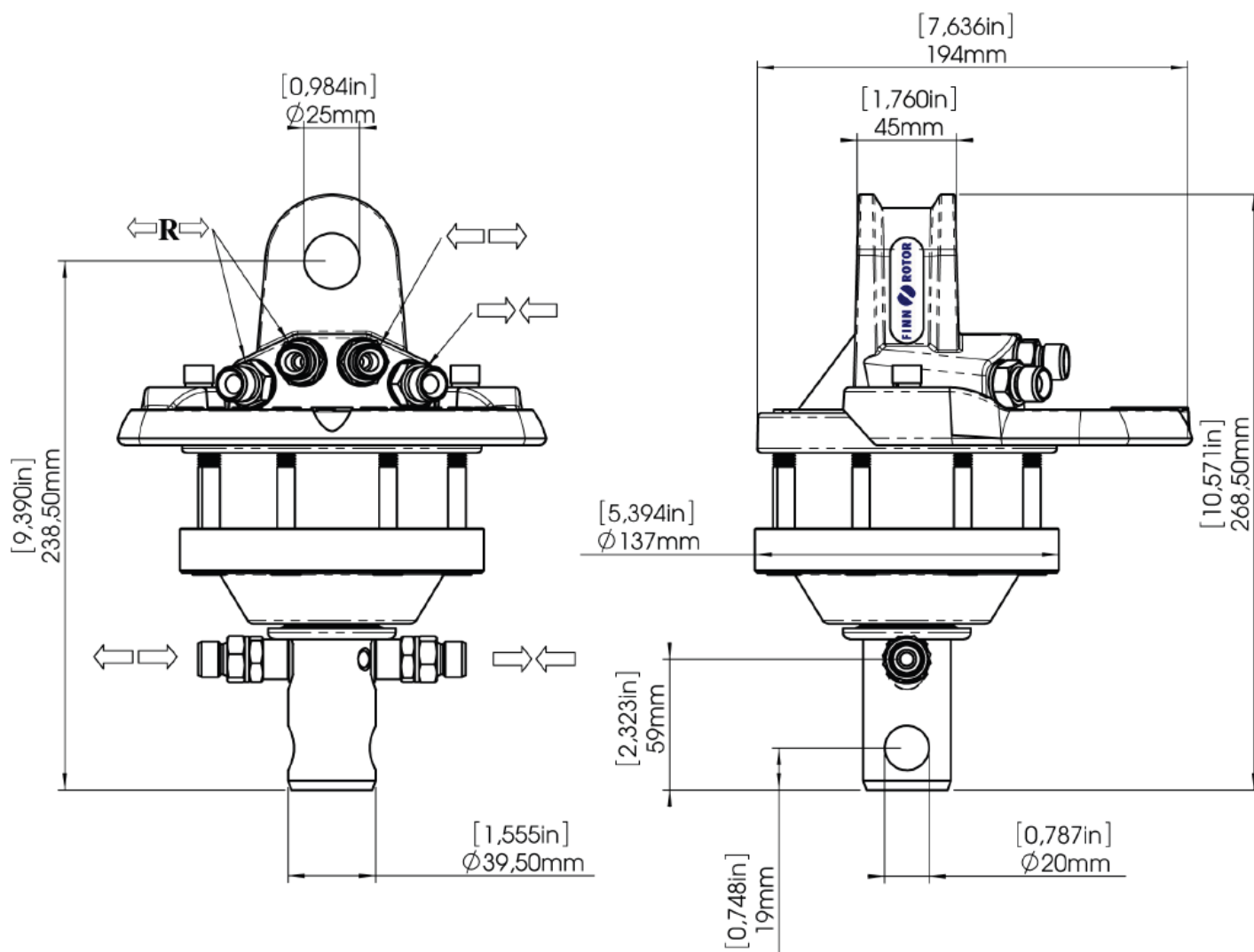

CR 100	
Unghi de rotație	nelimitat
Presiunea maximă de lucru:	250 bar
Cilindree:	193 cm ³
Cuplu:	450 Nm
Forța axială statică:	10 kN
Forța axială dinamică:	5 kN
Greutate:	10 kg